

GILDOR

AUTOMATIC BIFOLDING DOOR

MODEL FFM

INSTALLATION MANUAL

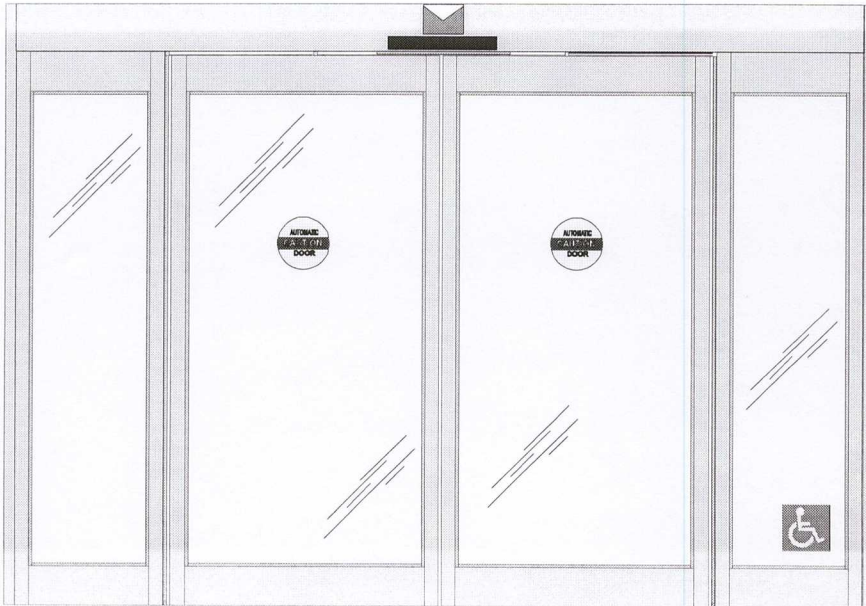
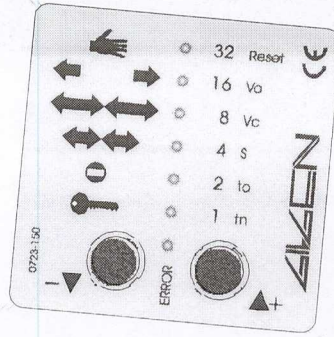

DISTRIBUTED BY:

DRIVES BY:

NICE

General

This manual for the FFM folding door:

- Supplies precise instructions for the assembly, the commissioning, the maintenance and troubleshooting.
- Is destined for the specialized personnel from the aluminum construction and electrotechnical trades, who have been accordingly authorized by the relevant authorities.
- Is divided into basic instructions as well as various instructions for optional equipment.

The present basic instruction contain all the specifications for the basic equipment of the FFM folding door.

The instructions for optional equipment are included in the deliveries of the optional KITS. Referring to the basic instructions, they describe the assembly and commissioning of the respective option.

- Uses the following signs in order to point out certain dangers and important remarks:



Warning:
Involving danger to life and limb.



Attention:
A situation where material could be damaged or the function impaired.



Note:
Hints which facilitate the work.

- Is handed over to the customer together with instructions for the optional equipment and operator manual.

Product Description

Folding wing door drive unit in modular design with a DC motor (Dual motor booster/redundent drive is an available option), microprocessor control unit and electronic control panel with patented bus-system (two-wire line).

The individual modules (KIT-system) and options are supplied in accordance with the order.

The folding wing door drive unit is connected to the main power supply by means of power cables from local power supply.

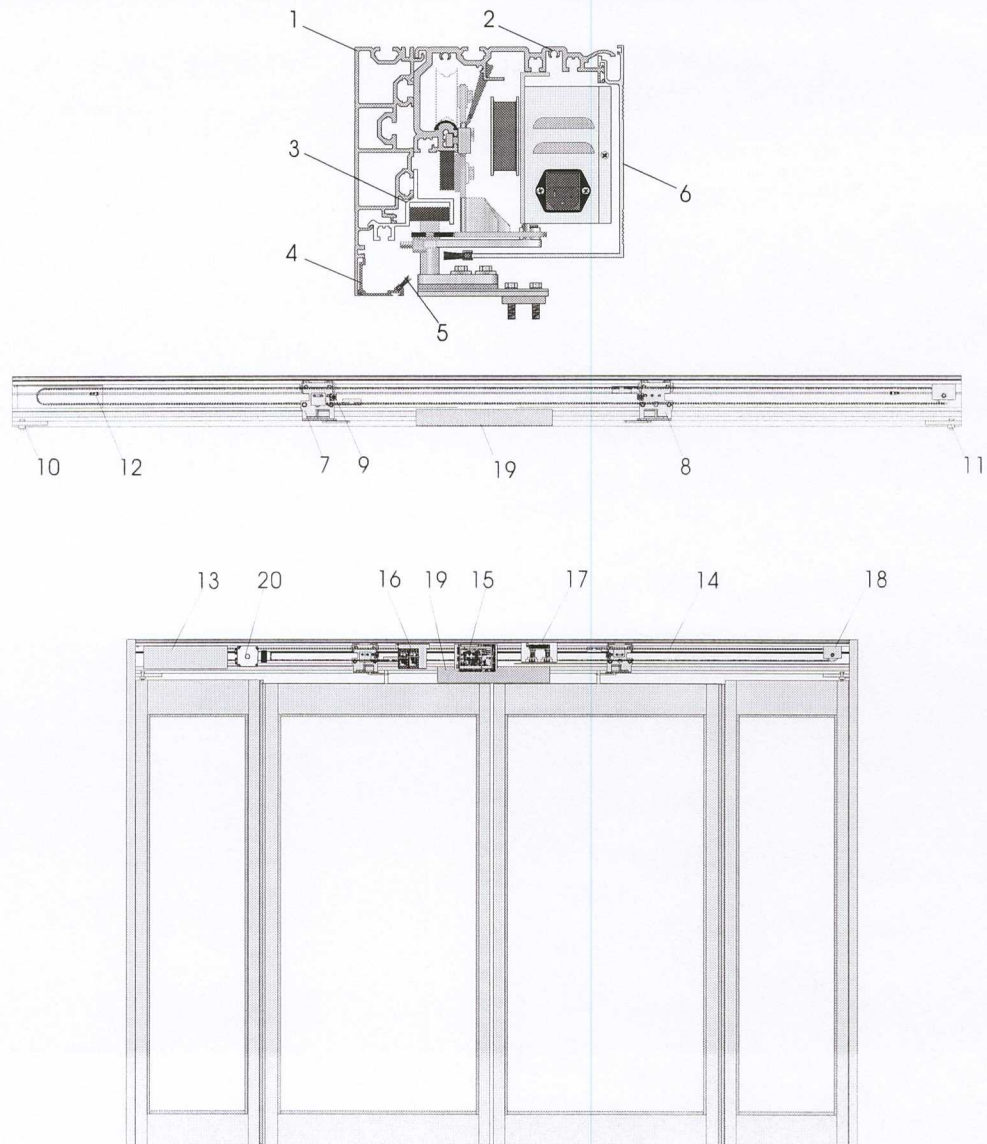

- | | | | |
|----|--------------------------------|----|--|
| 1 | Supporting profile | 12 | Stop Piece Outside |
| 2 | Carrier profile | 13 | Motor |
| 3 | Guideway profile | 14 | Drive Belt |
| 4 | Bottom Covering profile | 15 | Control Box |
| 5 | Bottom Weatherstripping | 16 | Emergency Battery |
| 6 | Front Access Cover | 17 | Holding Relay Bank |
| 7 | Traveling carriage Right | 18 | End Pulley |
| 8 | Traveling carriage Left | 19 | Electric Locking |
| 9 | Belt Bracket and Extension Arm | 20 | Electical Conneciion Box w/Transformer |
| 10 | Wing Bearing Pivot Right | | |
| 11 | Wing Bearing Pivot Left | | |

Area of application

Type	Designation	Clear passage width	Max. weight per folding wing	Max. wing speed
Bi-Folding	FFM	48...80inchs	155 pounds	0,5...0,7 m/s

Attention:

The application limits of the folding wing door FFM-Redundant are also defined in the sales documentation. Any applications beyond these limits are not advisable

Technical data

Electric connection to customer-supplied mains socket
Mains cable is included

120 V \pm 10%, 50/60 Hz, 15A

Power consumption

Max 4 amp. 1 amp. operating

Max. driving power (static)

150 N

Emergency opening

In cases where the width of the escape way is up to 78 inches, the drive mechanism must achieve 80% of the opening within three seconds. If the escape way exceeds 78 inches, the time value is proportional.

Ambient temperature

-15° C to + 50° C

The unit may only be used in dry rooms

max. relative humidity 65%

Protection rating

IP 23

Security

When designing the door installation, make sure that the relevant local guidelines for avoiding squeezing possibilities of pedestrian traffic are observed

Upon commissioning of the door, the opening and closing speeds are automatically adjusted in dependence of the wing weights, so as to eliminate any risks to the door users.

All the safety elements have to be checked with regard to their faultless function.



Attention:

A faultless functioning of the Gildor products can only be guaranteed on condition that they are used in conjunction with the original Gildor accessories (control elements, safety elements...), otherwise Gildor declines all responsibility for a safe and reliable functioning of the installation.

Installation header unit and drive

Check width and height of opening to verify FFM door package will fit. Check also for uneven floor and wall conditions. Check for floor high spots. (Door package must be set to highest point in the floor.)

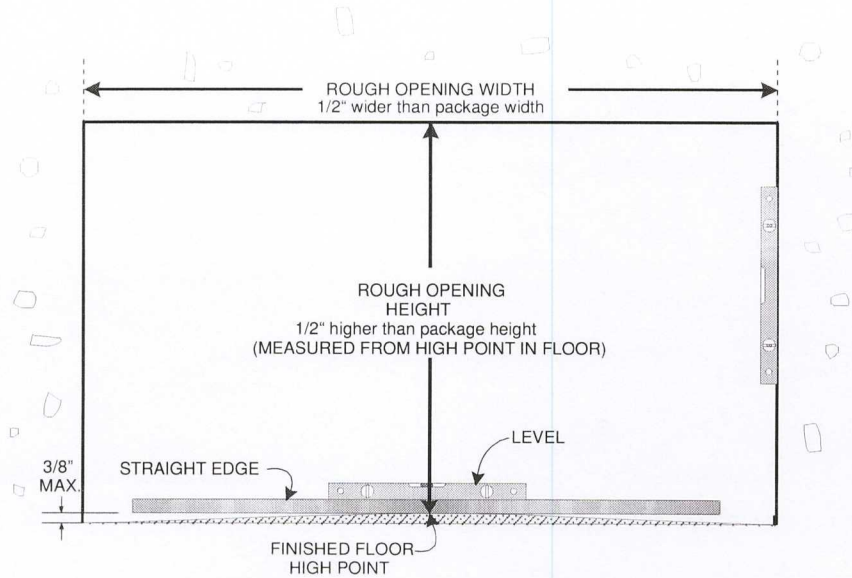

Attention:

In the event of an slanted floor surface, or if the floor is not even, the header must be set to high point and level. The FFM unit must have a perfectly level installation or door alignment will be impossible.

Jamb tube installation

1. Jamb tubes are handed and are labeled showing direction to face towards access cover.

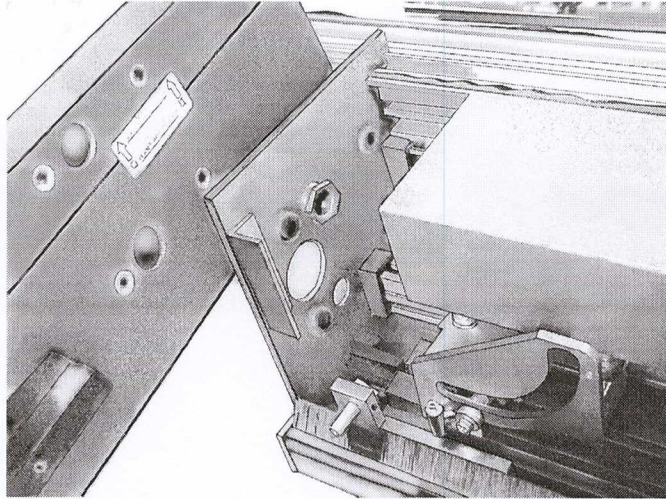

2. Install correct handed jamb tube and secure with hex bolts and flat washers provided. Before tightening make sure jamb tube is properly aligned against header.

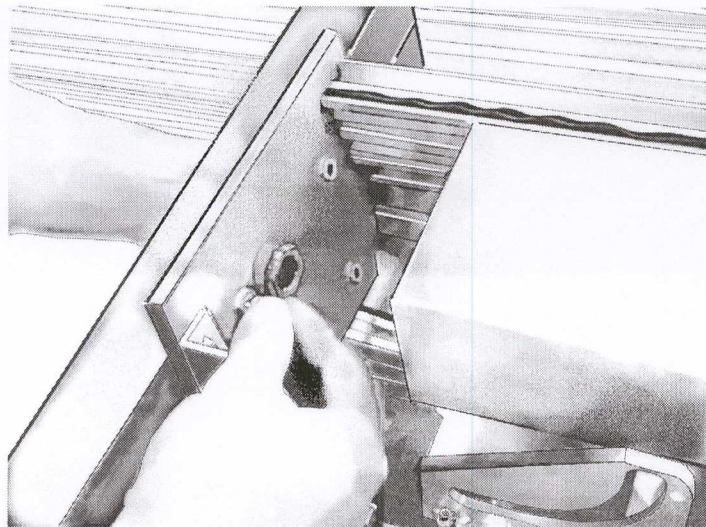

Header installation

1. Raise header into opening . The access cover always faces in the opposite direction of egress. Normally to the interior. Anchor to wall. 1" fingerguard can be removed to hide installion anchors. Anchoring should occur approx. 6" from under header and 6" from floor. Also a third anchor in center of these two first holes. Shim as required to assure a plumb and level jamb and header. After jambs have been anchored securely caulk both interior and exterior jamb locations. Header should only be caulked at exterior. Caulking interior around top of header cover may make it difficult to open header access cover fully.

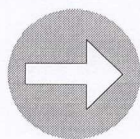
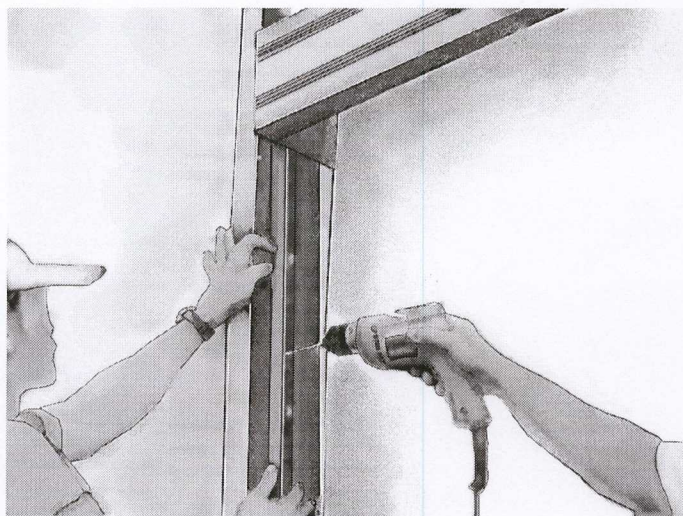

The access cover faces the opposite direction of panic breakout. Normally to the interior of the building.

Mounting the wings

1. Locate and align bottom pivot receiver with the jamb mounted pivot

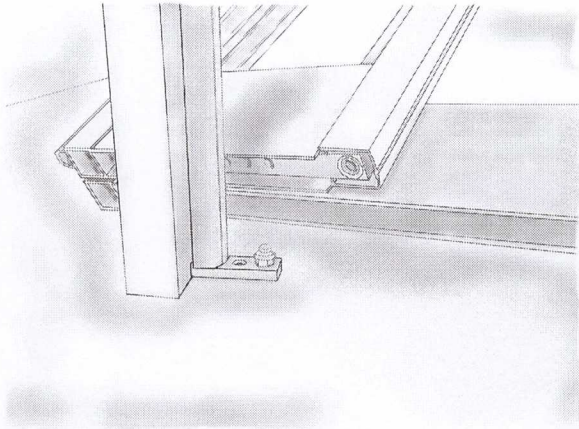

2. Fold doors leafs and place the wings on the bottom jamb mounted pivot.

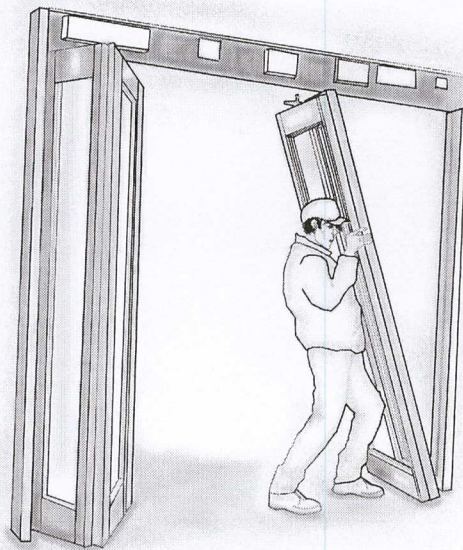

3. Tilt the door wings below the rotation pin while at the same time pushing the guide roller of the rotating lever into the guideway profile and inserting the roller of the rotating lever into the cam plate.

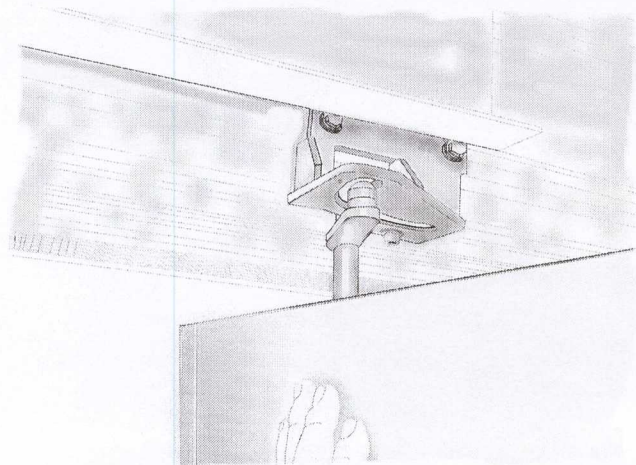
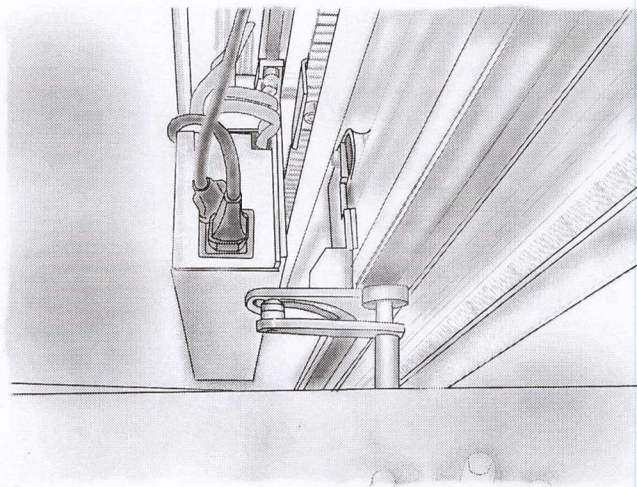
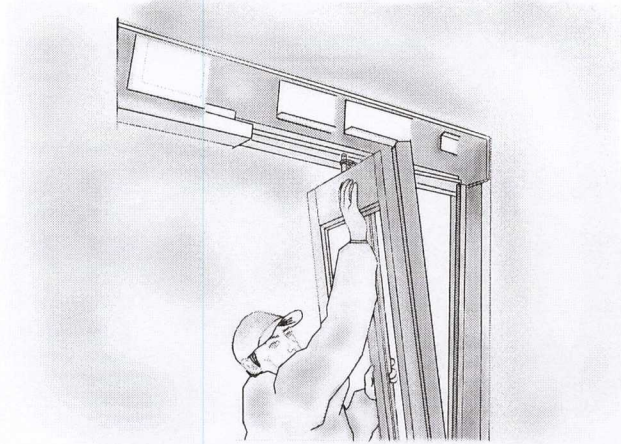

4. Align door top pivot receiver with the hole in the top pivot bracket.

5. Place door pivot screw through pivot bracket located at the top pivot edge of the header. Push pivot bolt down into top pivot receiver in the top rear edge of door wings. Tighten pivot bolt with open end wrench. Tighten the set screw on the side of the top pivot bracket.

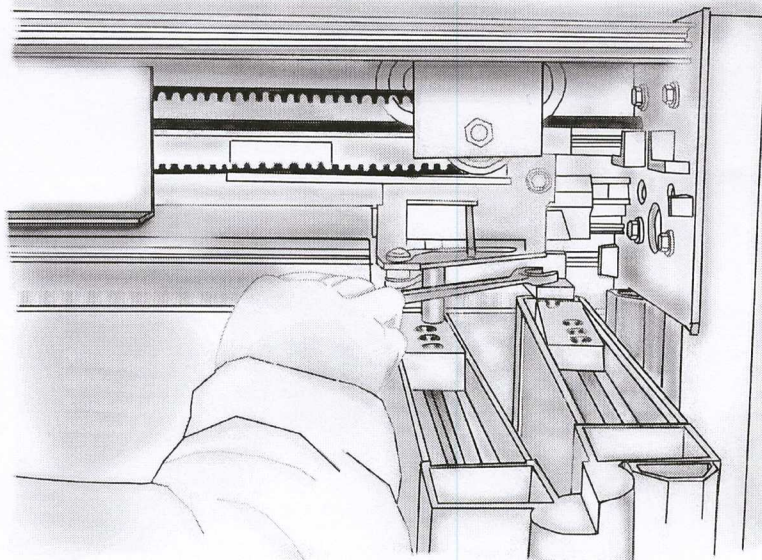
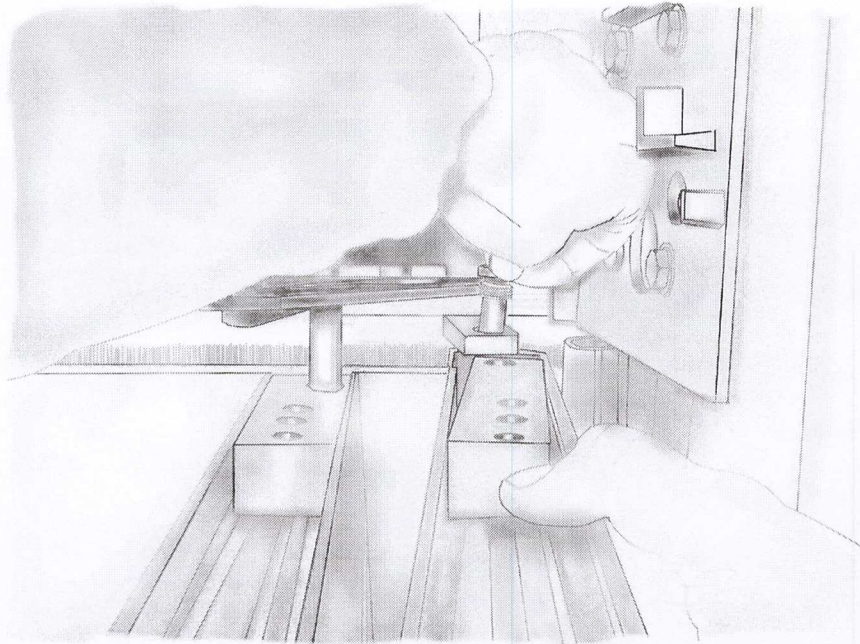

Height adjustment of the door wings are possible by adjusting the jamb mounted pivot bolt using thin open end wrench. Turning bolt clockwise will lower door panel. Turning bottom pivot bolt counterclockwise will raise door wings.



Attention:
When the wings are closing, the top of the secondary wing must not rub against the bottom of the covering profile. **Keep a distance of at least 1/16".**

Height adjustment of the door wings may have to be made. Allow rotating pivot bearing to protrude through cam lever leaving approximately 1/8" between pivoting lever and bottom of cam plate.

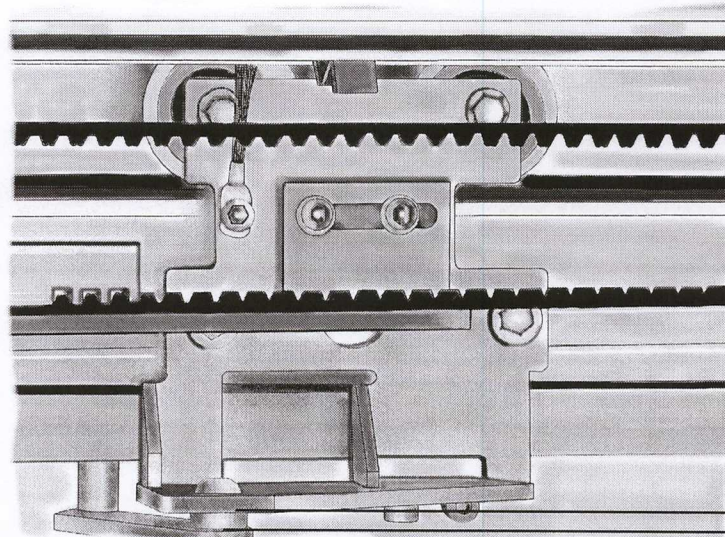

1/8"

Adjusting possibilities of the full open position.

1. The wider lead leaf must be at a 90 degree to jamb tube when the door wings are fully open. This adjustment is made by loosening the 3 phillips flat head screws and moving the pivoting lever mounted in the center of the wider door wing back or forth until door is at its 90 degree position.
Retighten 3 phillips flat head screws once adjustment is made.

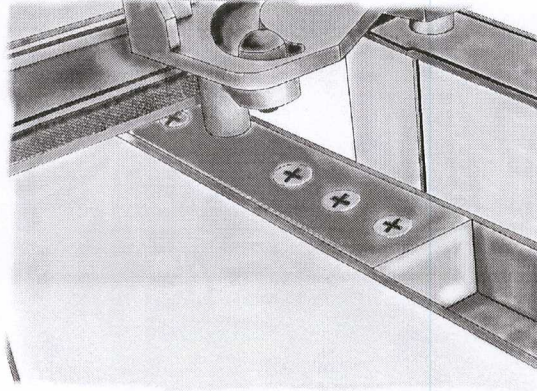

3. In the CLOSED position, check if the wings are aligned **parallel** to the drive unit. If not, slightly open the wings and slightly loosen the respective hexagon head cap screws of the belt bracket. Minor adjustment can be made here.
4. Slightly turn the rotating lever on the wing inward.
5. Slightly tighten the hexagon head cap screws.
6. By means of the traveling trolley and by simultaneously pressing a hand against the hinge area, completely close the folding wings.
7. Tighten the hexagon head cap screws of the belt bracket.

Exterior Sensor Extension

Exterior side of header must have a extension added to the motion sensor. This extension allows the motion sensor pattern to be extended past the lead edge of the closing door wings to prevent recycling. The header and extension is preped for easy installation.

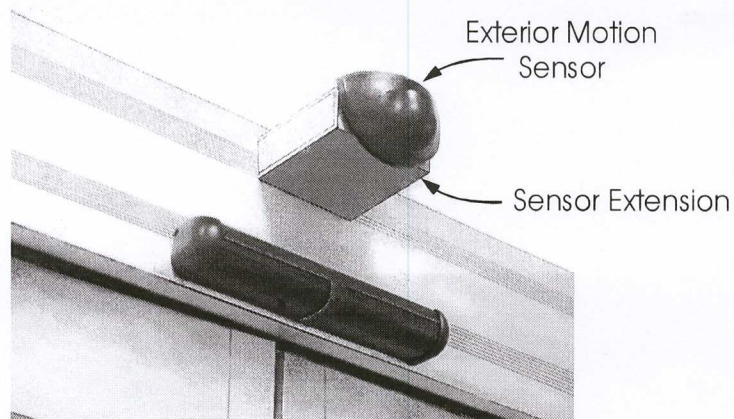

Emergency battery backup

Assembly position in the carrier profile. See respective drawing "KIT-Installation" (in accessory instructions).

1. Install the emergency battery as shown in the illustration.

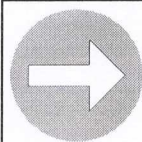

Note:
The connection of the emergency battery is to be done after mains power is initiated.



Warning:
An incorrect connection is liable to cause accidents or damages to the material.

Control panel BEDIS

The location of control panel (29) is determined by the project management during the planning of the installation. Necessary installations (provided by customer), power supply and connecting cable (30).



Attention:
Length of the connecting cable to the Bedis from Control box is max. 150ft. . A shielded cable must be used.

1. Branch the BEDIS connecting cable (30) to terminals 25/26 on the control PCB, according to diagram on the control unit. The shielding must be fastened to the subconstruction of the control unit (25). The shielding (31) must be fastened to the subconstruction of the control unit (25) by means of the clamp (32) and the screw (33).
2. Branch the connecting cable (30) to terminals 1/2 on the BEDIS PCB. The shielding (31) must be fastened to the subconstruction of the Bedis by means of the clamp (34), the screw and the hex-nut (35).

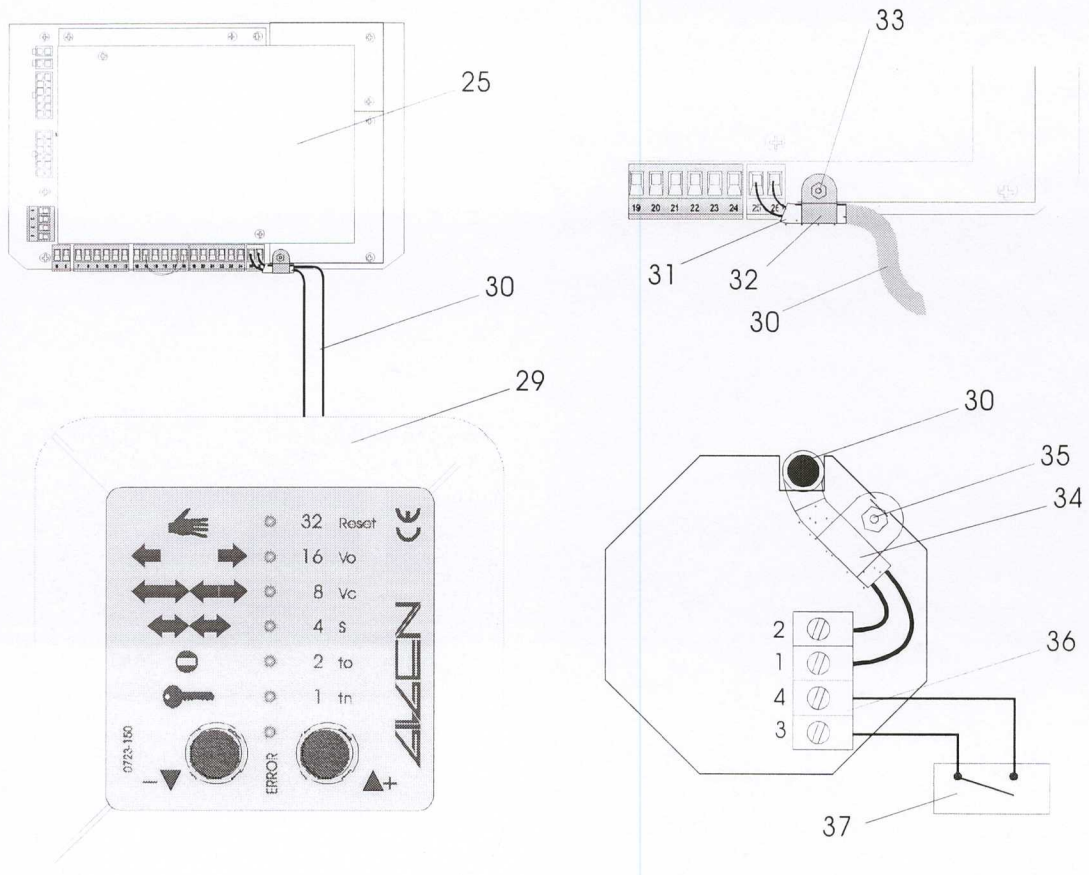

BEDIS Lock

1. To lock BEDIS (29), dismantle strap (36), terminals 3/4, and replace for example with a de-activated switch or momentary contact rocker switch (37).

COMMISSIONING

Requirements

- All the components and elements of the “Basic KIT” as well as of the options have been mounted, aligned and cabled as described.
- Any additional control and safety elements have been mounted and connected.
- The sliding wings are easily moved.

Preliminary electrical settings

Connect the emergency battery with the Microprocessor control.

The travel distance as well as the maximum admissible speeds and forces are set automatically by the drive unit during the setting-up procedure (RESET).

Setting-up procedure:

The setting-up procedure is carried out during the commissioning of the drive unit or a RESET entered via the control panel.

- During the first commissioning, all the values of the 2nd level are set to standard.
- If a RESET is made after the door has already been operated:
see 2nd level.
- After the first commissioning, all the values of the 2nd level remain memorized after a mains power failure.

Procedure:

1. Test of all the hardware elements of the control unit.
2. All the connected elements are checked (BEDIS, BATTERY).
3. The door closes as far as the CLOSED position with a set-up speed of 0.075 m/s.
4. The door opens with a set-up speed of 0.075 m/s as far as the OPEN-position stop. During the opening the locking is checked (path 1 1/2") and a mean value of friction is determined. After an opening distance of approx. 4", the Motor drive unit is tested as follows:
 - The door closes and opens twice, for half a second each.
 - Then the setting-up procedure continues normally.
5. The mass is measured with a short acceleration of the wing. This mass also determines the maximum speed.
6. The door closes as far as the CLOSED position.
7. By initiating two emergency openings, the system checks if the emergency opening elements are capable of reaching 80% of the opening width within the required time. If the required time is exceeded, the door remains open and a respective error message is displayed on the control panel.
In this case:
 - The mechanical settings have to be checked.
 - Remove the jumpers from both drive units (see chapter 3.2).

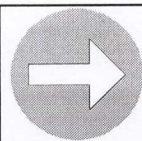

Note:
Upon the 1st commissioning, or when softswitch no. 1 (3rd level) is ON, the control fixes a lower time record.

8. The door closes as far as the CLOSED position.
The closing speed corresponds to 65% of the max. opening speed.

Procedure

1. Move the sliding wings to the center position.
2. Plug in both power plugs.
On control unit, LED 5 V (1), 5 V (2), 24 V and Power are lit.
3. Carry out a RESET.
4. On the control panel the LED 32 flashes after plug-in until the setting-up has been successfully terminated.
 - In order to enable the installation to set itself up, the program position AUTOMATIC must be activated.
 - If another LED is lit along with the flashing LED 32, then the corresponding operating function is set.
 - If the required time cannot be achieved, the door remains open and a respective error message is displayed on the control panel (error no. 5 or 6).
In this case:
 - The mechanical settings have to be checked according to chapter 3
 - Remove four jumpers according to chapter 3.2.
 - Carry out a RESET:
The installation sets itself up (repeat until OK).

Interferences

The setting-up procedure can be affected by the following interferences:

- Key-operated program switch is on Night (#1 of Bedis).
- Control panel is on MANUAL.
- Excessive friction of the door system.
- The door opens first during set-up:
Check the assembly position of the belt coupling as per drawing "KIT-installation".
- The safety elements are not connected or have been triggered.
- Red ERROR LED is flashing along with red LEDs.
- Check the fine-wire fuse in the mains filter on drive units Motor.
- Defective control unit.